

**INSTRUCTION MANUAL FOR DETACHED PIR SENSOR
DAYLIGHT HARVEST, MODEL NO.:HC038V / HCD038 + HIR01**

Technical Specifications

PRODUCT TYPE:	PIR Sensor
OPERATING VOLTAGE:	220-240VAC 50Hz/60Hz
RATED LOAD (for HC038V):	400W (capacitive load)
OUTPUT (for HCD038):	Max. 15 devices, Max. 30mA
DETECTION ANGLE:	360°
POWER CONSUMPTION:	<1W
DETECTION RANGE (DxH):	Max. 6 x 3m(for HIR01)
HOLD TIME:	30s ~ 30min.
STAND-BY PERIOD:	0s, 10s ~ 1h, +∞
STAND-BY DIMMING LEVEL:	10% ~ 50%
MOUNTING:	Indoors, ceiling & wall mounted
WORKING TEMP.:	-20 ~ +60°C

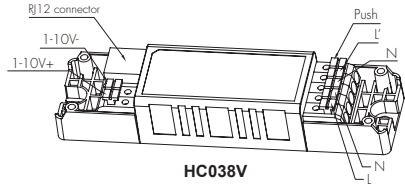

HC038V

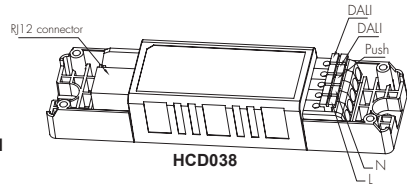

HCD038

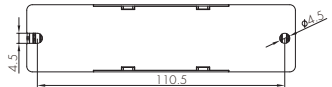
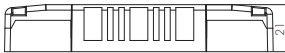

PIR Sensor Head

Model: HIR01

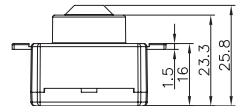
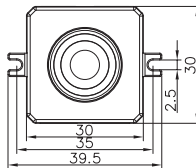
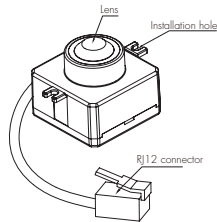

IMPORTANT

PLEASE READ THESE INSTRUCTIONS CAREFULLY PRIOR TO INSTALLATION AND RETAIN THIS LEAFLET IN A KNOWN AND SAFE PLACE FOR FUTURE REFERENCE.

SECTION 1 INSTALLATION AND WIRING

1.1 Ensure that the electricity supply is switched off before installing or servicing this product.

1.2 Wiring diagram

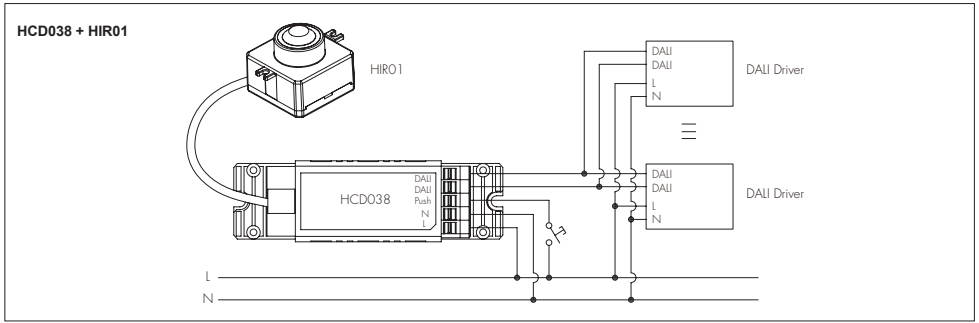
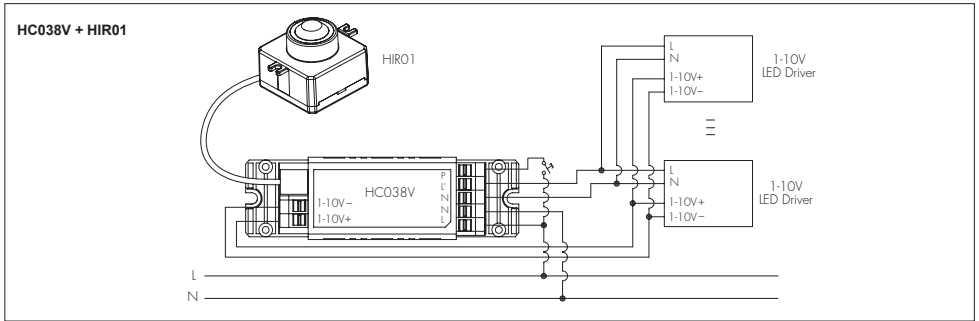

SECTION 2 REMOTE CONTROL

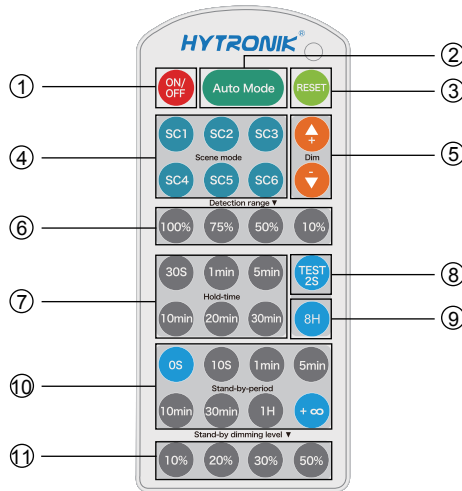

HRC01

Permanent ON/OFF [button ①]

1. Press the button ①, the light goes to permanent ON or permanent OFF mode.
2. Exit this mode by pressing button ② ③ ④ ⑤. (Please refer to explanation accordingly)

Auto Mode [button Ⓜ]

Press button Ⓜ goes to auto mode, the sensor starts working and all settings remain the same as the latest status before the light was switched ON/OFF.

RESET [button Ⓝ]

Press button Ⓝ, all existing settings go back to factory-set value. (See table below)

Detection range	Hold time	Stand-by period	Stand-by dimming level	Constant LUX
100%	5min	10min	20%	100Lux

Test 2s function [button Ⓜ]

1. Press button Ⓜ, the sensor goes to test mode (hold time 2s), stand-by period and daylight sensor are disabled.
2. Exit test mode by pressing buttons in zone Ⓝ④⑦, and the sensor setting is changed accordingly.

8H permanent on mode [button Ⓜ]

1. Press the button Ⓜ, the light will be 100% on for 8 straight hours even there is no motion detected.
2. After 8 hours, the sensor goes to auto mode directly.
3. Exit this mode by pressing button Ⓝ②③④ (Please refer to explanation accordingly).

Detection range [zone Ⓜ]

The buttons in zone Ⓜ is disabled.

Hold time [zone Ⓜ]

Press the buttons in zone Ⓜ to set hold time at 30s / 1min / 5min / 10min / 20min / 30min.

Stand-by period [zone Ⓜ]

Press the buttons in zone Ⓜ to set stand-by period at 0s / 10s / 1min / 5min / 10min / 30min / 1H / +∞.

Note: "0s" means on/off control; "+∞" means 2 steps of dimming control, light never switches off.

Stand-by dimming level [zone Ⓜ]

Press the buttons in zone Ⓜ to set the stand-by dimming level at 10% / 20% / 30% / 50%.

Constant lux value setting [zone Ⓜ]

1. Long press the buttons in zone Ⓜ to adjust the fixture's brightness. ⊕ means dim up, ⊖ means dim down.
2. Stop pressing the button when get the target brightness.
3. The built-in daylight sensor reads the available ambient lux level and adjust electrical brightness to maintain the constant lux value.

Scene mode options [zone Ⓜ]

There are 6 scenemodes for different applications:

Scene options	Detection range	Hold time	Stand-by period	Stand-by dimming level	Constant Lux
SC1	100%	1min	1min	10%	50Lux
SC2	100%	3min	5min	20%	75Lux
SC3	100%	5min	10min	20%	100Lux
SC4	100%	10min	30min	30%	150Lux
SC5	100%	20min	1h	30%	200Lux
SC6	100%	30min	+∞	50%	400Lux

Note: end-user can adjust the settings by pressing buttons in zone Ⓜ⑦⑩⑪, the last setting stays in validity.

SECTION 4 FUNCTION

4.1 Manual Override

This sensor maybe over-riden by the end-users to switch on/off the lights manually, or adjust the maximum brightness during motion hold-time with the push-switch. This makes the product more user-friendly and offers more options to fit for extra-ordinary demands.

* Short push (<1s): on/off function;

ON → OFF: the light turns off immediately and cannot be lighten for a certain time (equals to hold time preset) even there is movement is detected. After this period, the sensor goes back to auto sensor mode.

OFF → ON: the light turns on 100% and goes to auto sensor mode, even when ambient Lux level exceeds the daylight threshold.

* Long push (>1s): adjust the maximum brightness (between 10% and 100%) during hold-time. Both the settings on DIP switch and manual override can overwrite each other, the latest action controls.

* If no end-user adjustment is desired, simply leave this terminal disconnected.

4.2 Loop-in and Loop-out Terminal (HC038V)

Double L N terminal makes it easy for wire loop-in and loop-out, and saves the cost of terminal block and assembly time.

SECTION 5 TROUBLE SHOOTING

MALFUNCTION CAUSE REMEDY	CAUSE	REMEDY
The light will not come on	Incorrect light-control setting selected	Adjust daylight threshold setting
	Faulty lamp	Replace lamp
	No power supply	Check power to sensor
The lamp is always on	Continuous movement in the detection zone	Check detection area setting
The lamp is on without any identifiable movement	The sensor is not mounted for reliably detecting movement	Securely mount enclosure
	Movement occurred, but not identified by the sensor (Movement behind wall, movement of small object in immediate lamp vicinity etc.)	1. Reduce sensitivity. 2. Check the movement behind walls to avoid facilities such as water pipe, fan, which may mis-trigger the sensor.
The lamp will not work despite movement	Rapid movements are being suppressed to minimize malfunctioning or the detection radius is too small.	Check detection area setting