

Multi-Directional HF Sensor

HMW27/AA

DALI Output & Tri-level Dimming

HYTRONIK®







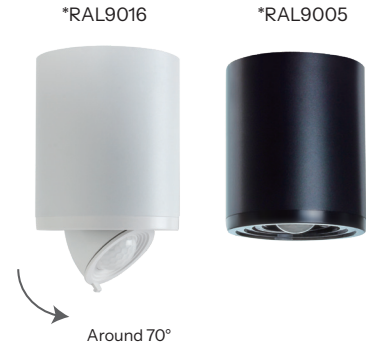



Product Description

HMW27/AA is a HF standalone motion sensor, with one DALI channel output (80mA DALI power supply built-in). It is designed with a metal surface mount box and the detection angle is adjustable by needs. HMW27/AA is ideal for typical indoor applications such as offices, classrooms, healthcare, and other commercial areas (corridors and warehouses).



Features

-  Tri-level dimming control based upon occupancy (also known as corridor function).
-  Intelligent photocell - lights and sensors only operate when needed, natural light has priority.
-  DALI bus power supply
 - I guaranteed: 64mA
 - I max: 80mA
 - U rated: 15VDC
-  Support to control DT6 LED drivers
-  1 Push inputs for flexible manual control
-  Black & White & Gray metal surface mount box options
-  User-friendly design for installation
-  5-year warranty

Technical Specifications

Input & Output Characteristics

Operating voltage	220~240VAC 50/60Hz
Stand-by power	<1W

DALI Bus Power Supply

I guaranteed	64mA
I max	80mA
U rated	15VDC

Sensor Data

Sensor Principle	High Frequency (microwave)
Ceiling-mounted Detection Range	Installation Height : 3m Max. Detection Range : 13m *Sensor head angle set to 70°
Wall-mounted Detection Range	Installation Height : 2.5m Max. Detection Range: 22m
Detection angle	360°

Environment

Operation temperature	Ta: -15°C ~ +45°C
Storage temperature	-40°C ~ +70°C
Relative humidity	20~90%
IP rating	IP20

Safety & EMC

EMC standard (EMC)	EN55015, EN61000-3-2/-3-3, EN61547
Safety standard (LVD)	EN60669-1, EN60669-2-1
RED	EN300328, EN301489-1/-17, EN50663
Certification	CE, UKCA, RED, RCM

* For more details of detection range, please refer to "detection pattern" section.

Mechanical Structure & Dimensions

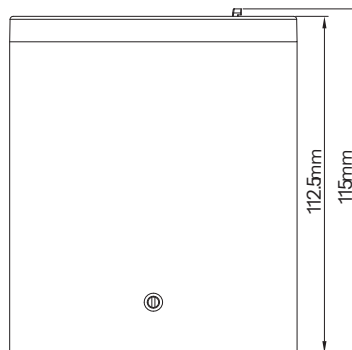
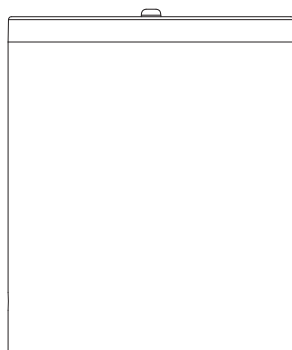
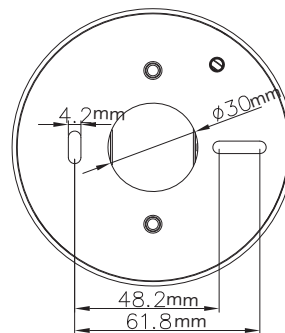
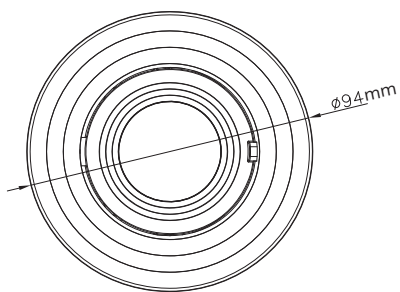
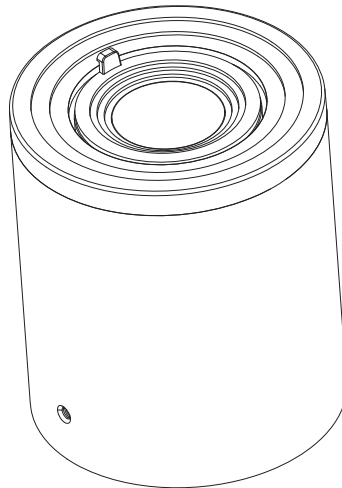

Wiring Diagram

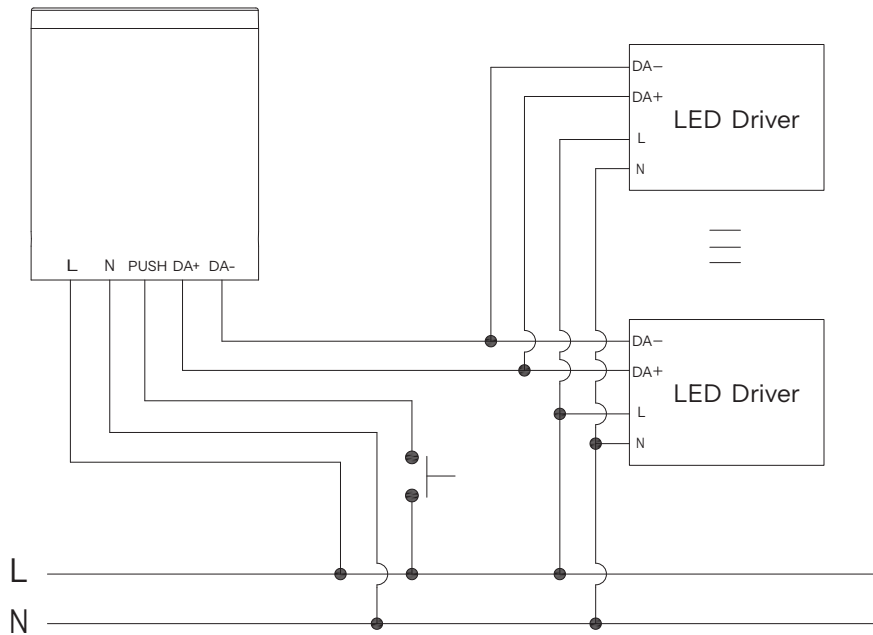

1. 200 metres (total) max. for 1mm² CSA (Ta = 50 °C)
2. 300 metres (total) max. for 1.5mm² CSA (Ta = 50 °C)

—This product should be installed by a qualified electrician.

Detection Pattern

*Sensitivity set to maximum

Ceiling-mounted application

Installation height: 3m

*Sensor head angle set to 70°

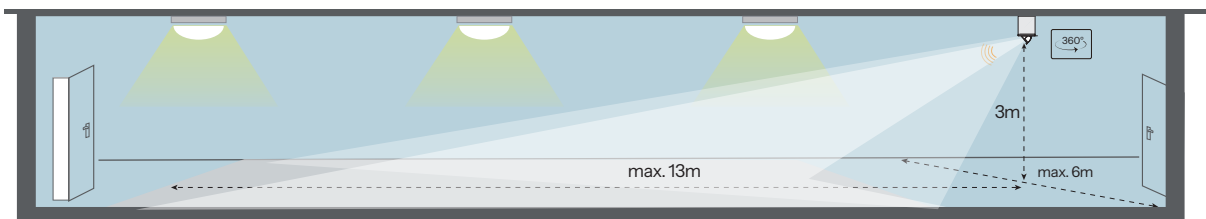

Installation height: 3m

*Sensor head angle set to 90°

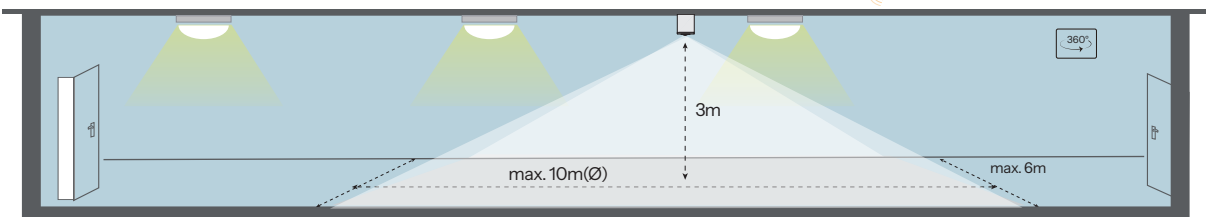

Wall-mounted application

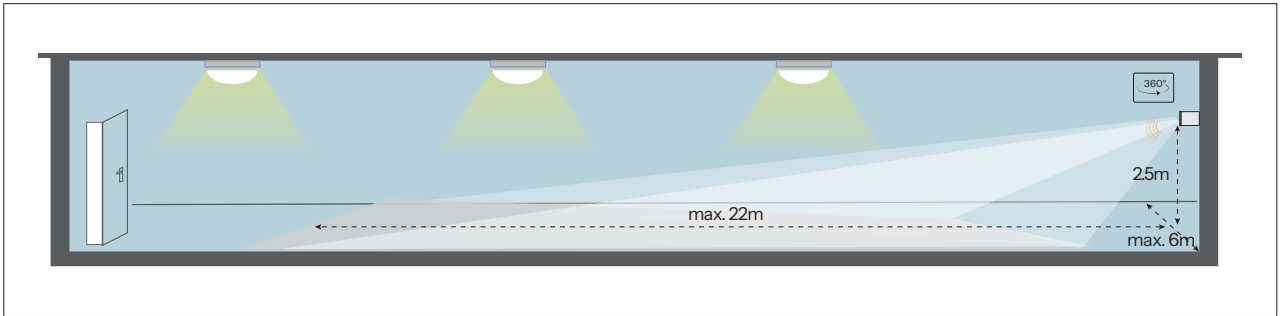

Application	Angle	Height	Sensitivity			
			100%	75%	50%	10%
Ceiling-mounted	90°	3m	10m(Ø)	8m(Ø)	6m(Ø)	4m(Ø)
		8m	14m(Ø)	5m(Ø)	none	none
	70°	3m	13m	11m	9m	7m
		8m	15m	7m	4m	none
Wall-mounted	90°	2.5m	22m	20m	16m	11m

Note: The unit of 90 degree detection data is diameter.

Ceiling-mounted application

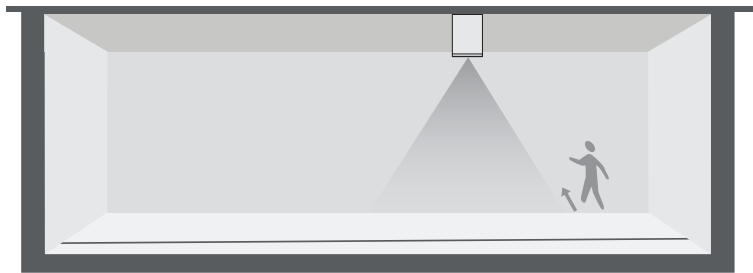
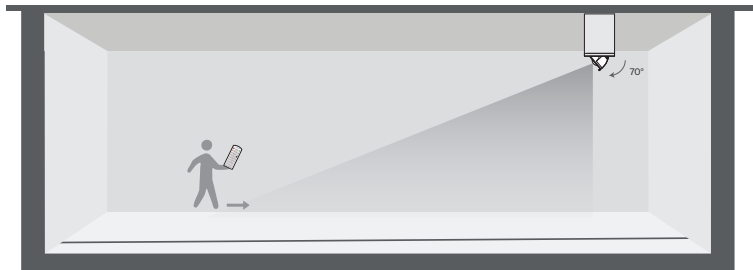

Wall-mounted application



Functions and Features

1. Tri-level Control

Hytronik builds this function inside the motion sensor to achieve tri-level control, for some areas which require a light change notice before switch-off. The sensor offers 3 levels of light: 100% → dimmed light (natural light is insufficient) → off; and 2 periods of selectable waiting time: motion hold-time and stand-by period; Selectable daylight threshold and freedom of detection area.

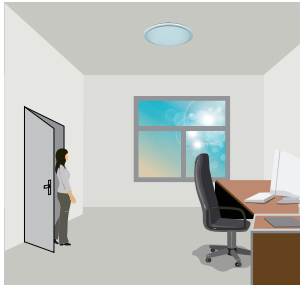

With sufficient natural light, the light does not switch on when presence is detected.

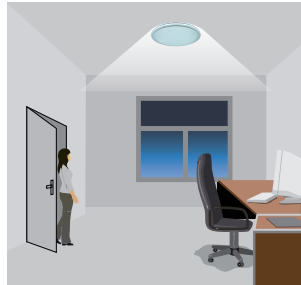

With insufficient natural light, the sensor switches on the light automatically when presence is detected.

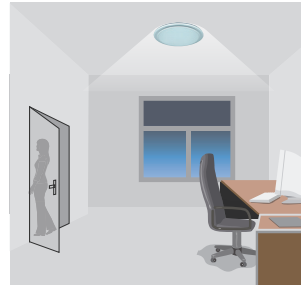

After hold-time, the light dims to stand-by level if the surrounding natural light is below the daylight threshold.



Light switches off automatically after the stand-by period elapses.

2. 24h Daylight Monitoring Function

Our innovative and patented software enables our antenna with built-in daylight sensor to provide a “smart photocell” function. This function is activated when stand-by period is set to “+∞”.

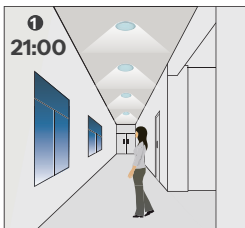

The light switches on at 100% when there is movement detected.

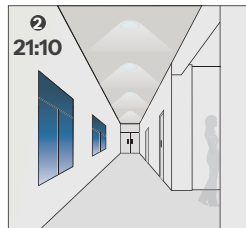

The light dims to stand-by level after the hold-time.

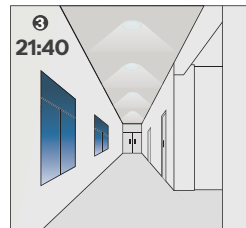

The light remains in dimming level at night.

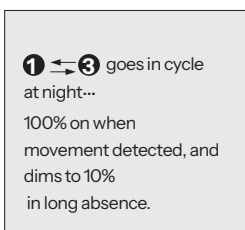

1 ↔ 3 goes in cycle at night... 100% on when movement detected, and dims to 10% in long absence.



The light turns off completely when natural light lux exceeds daylight threshold pre-set.



The light automatically turns on at 10% when natural light is insufficient (no motion).

Settings on this demonstration:
 Hold-time: 10min
 Daylight threshold: 50lux
 Stand-by dimming level: 10%
 Stand-by period: +∞

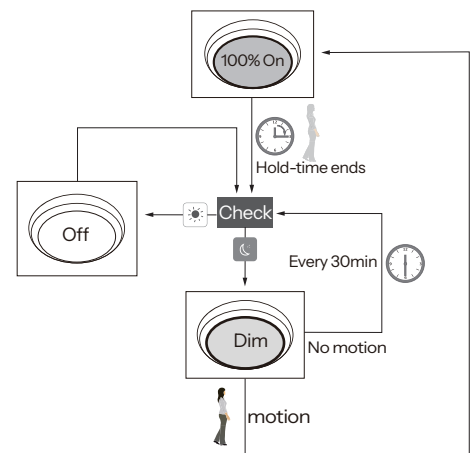

3. Robust HF Sensors Design --- Anti-interference Technology



Hytronik’s microwave motion sensor uses 5.8GHz high frequency (HF) antenna in the product design. With the increasing density of wireless environments such as 5G GSM tower and 5G Wi-Fi coverage, this has created extra challenges for sensor’s operation because the air is shared by all kinds of wireless signals, and transmissions from any device at the similar frequency could potentially cause interference. The effects of interference which can be noticed by users are usually false triggering of sensors (turning on/off erratically), or lights staying on even after hold time etc.

To get around such tough environment, Hytronik has developed a new series of robust HF modules, designed to be loaded with our own special sophisticated software algorithms. These robust HF modules can withstand differ-

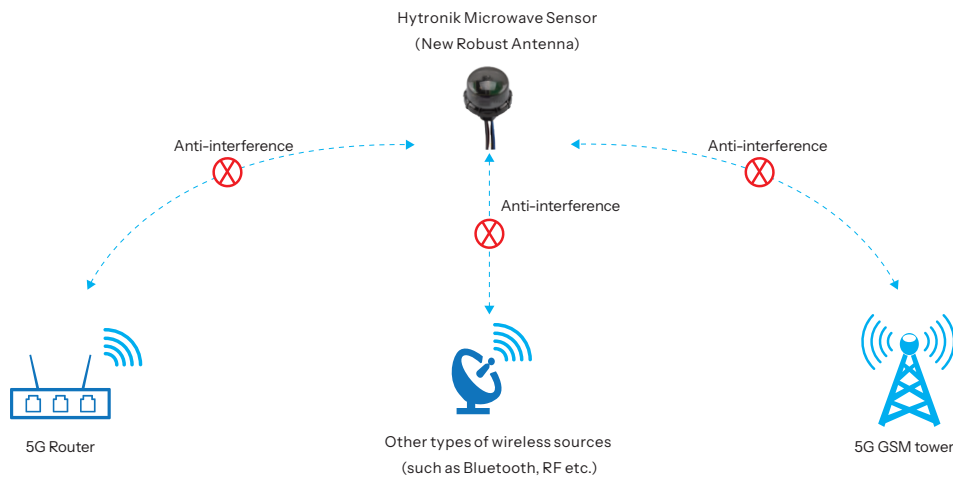

Settings (Remote Control HRC-05)



Permanent ON/OFF function

Press the “ON/OFF” button, the light goes to permanent on or permanent off mode, and the sensor is disabled.

* Press “Auto Mode”, “RESET” or “Scene mode” buttons to quit this mode. The mode will change to AUTO Mode after power failure.



Sensor mode

Press “Auto Mode” button, the sensor starts to function and all settings remain the same as the latest status before the light is switched on/off.



Reset function

Press “RESET” button, all settings go back to default settings.



Dim +/-

Long press “Dim +” or “Dim -” to adjust the target lux level during hold-time. “+” means increasing the target, “-” means decreasing the target.

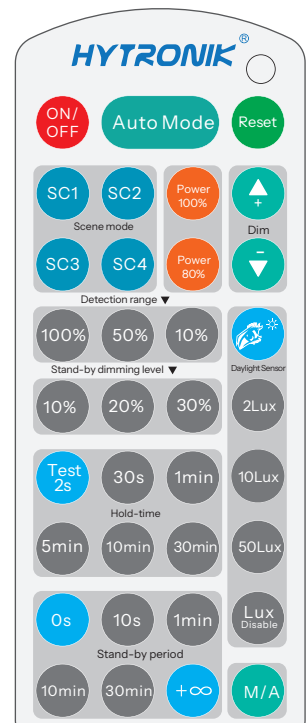

HRC-05

Note: the light will flash ONCE rapidly after receiving the command from the remote control successfully.



Test mode

This button is for testing purpose only. The sensor goes to test mode (hold-time is 2s) after commissioning, meanwhile the stand-by period and daylight sensor are disabled.

* This mode can be ended by pressing “reset”, or any button of “scene mode” and “hold-time”. The sensor settings are changed accordingly.



Power output



By pressing these two buttons, the output shifts between 80% (at initial 10,000 hours) and 100%, for energy saving purpose.



Lux disable

Press this button, the built-in daylight sensor stops working, and all motion detected could turn on the lighting fixture, no matter how bright the natural light is.

Scene mode

There are 4 scene modes fixed program built in the remote control to choose for different applications:

Scene options	Detection range	Hold-time	Stand-by period	Stand-by dimming level	Daylight sensor
SC1	100%	1min	10min	10%	2Lux
SC2	100%	5min	10min	10%	2Lux
SC3	100%	10min	30min	10%	10Lux
SC4	100%	10min	+∞	10%	50Lux

* End-user can adjust the settings by pressing buttons of detection range/hold-time/stand-by period/stand-by dimming level/daylight sensor. The last setting stays in validity.

Detection range

Press the buttons of “detection range” to set detection range at 10% /50% /100%.

Hold-time

Press the buttons of “hold-time” to set hold-time at 2s / 30s / 1min / 5min / 10min.

Daylight sensor

Press the buttons of “daylight sensor” to set daylight threshold at 2Lux / 10Lux / 50Lux. The fixture will not turn on if ambient natural light lux level exceeds the threshold preset when motion detected.

Stand-by period (corridor function)

Press the buttons of “stand-by period” to set stand-by period at 0s / 10s / 1min / 10min / 30min / +∞.

* “0s” means on/off control; “+∞” means bi-level dimming control, and the fixture never switches off.

Stand-by dimming level

Press the buttons of “stand-by dimming level” to set the stand-by dimming level at 10% / 20% / 30%.

Dimming Interface Operation Notes

Switch-Dim

The provided Switch-Dim interface allows for a simple dimming method using commercially available non-latching (momentary) wall switches.

Switch Function	Action	Descriptions
Push switch	Short press (<1 second) * Short press has to be longer than 0.1s, or it will be invalid.	- Turn on/off - Turn on only - Turn off only - Recall a scene - Quit manual mode - Do nothing
	Double push	- Turn on only - Turn off only - Recall a scene - Quit manual mode - Do nothing
	Long press (≥1 second)	- Dimming - Colour tuning - Do nothing

Additional Information / Documents

1. Regarding precautions for HF sensor installation and operation, please kindly refer to www.hytronik.com/download →knowledge →Microwave Sensors - Precautions for Product Installation and Operation
2. Regarding Hytronik standard guarantee policy, please refer to www.hytronik.com/download →knowledge →Hytronik Standard Guarantee Policy