

Motion sensor in combination with RF wireless communication

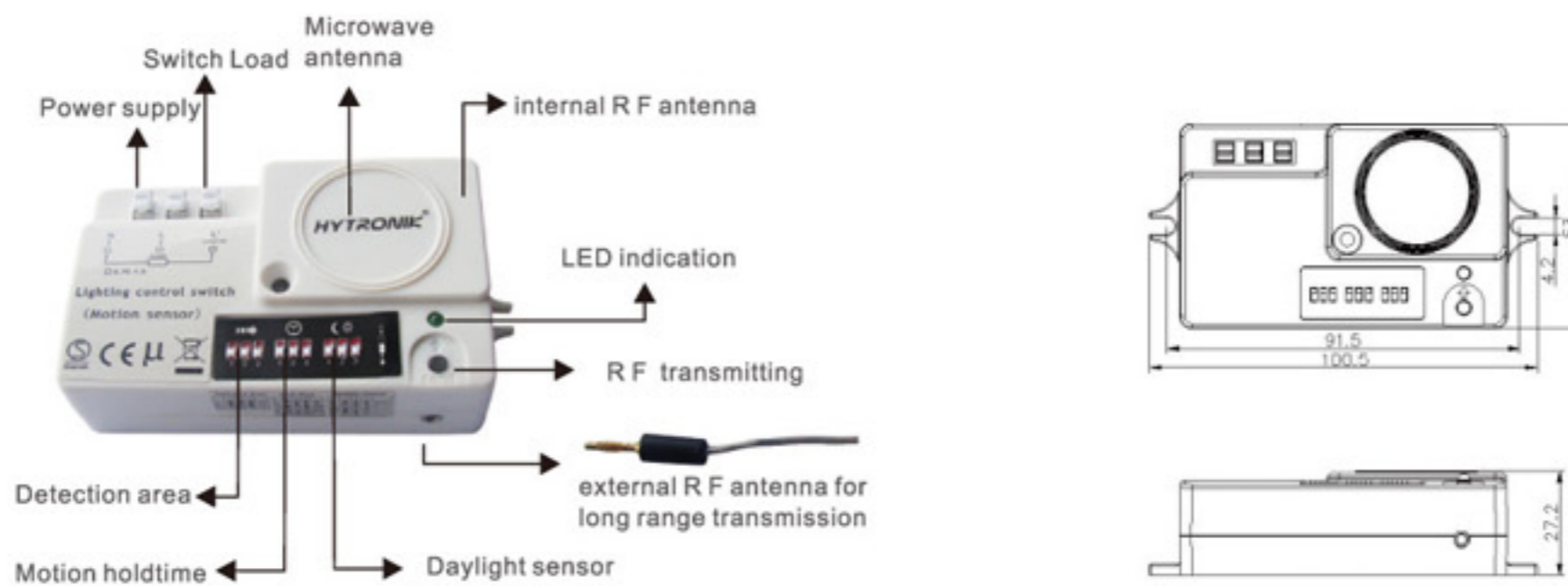

HC001S/RF Motion sensor + R F transmitter



HC002RF Economy R F receiver (on/off function))



HC005RF Advanced R F receiver (on/off & 1-10v output))

Output function:

This is a combination of motion sensor and RF radio wave wireless transmission. The motion at 1 sensor (the master unit) can be passed onto other pre-defined individuals (the slave units) through RF transmission. Up to 15 units can be programmed and grouped by means of teach-and-learn method. With KEELOQ coding technology, 1 master can trigger max. 15 slaves at the same time, and 1 slave can respond up to 15 masters respectively.

With both 1-10v output signal and 220-240v signal, it can switch on/off any lighting applications, and dim fluorescent lamps, HID lamps as well as LED lamps.

1 : HC001S/RF + HC002RF to have on/off function with non-dimmable ballast--

HC001S/RF + HC002RF can switch on/off halogen transformer, non-dimmable fluorescent ballast, non-dimmable LED drivers. However, there is a limit of max. load due to the inrush current.

max. Load (inductive load)--

HC002RF:

200w@100v; 400w @ 230v; 500w @ 277v;

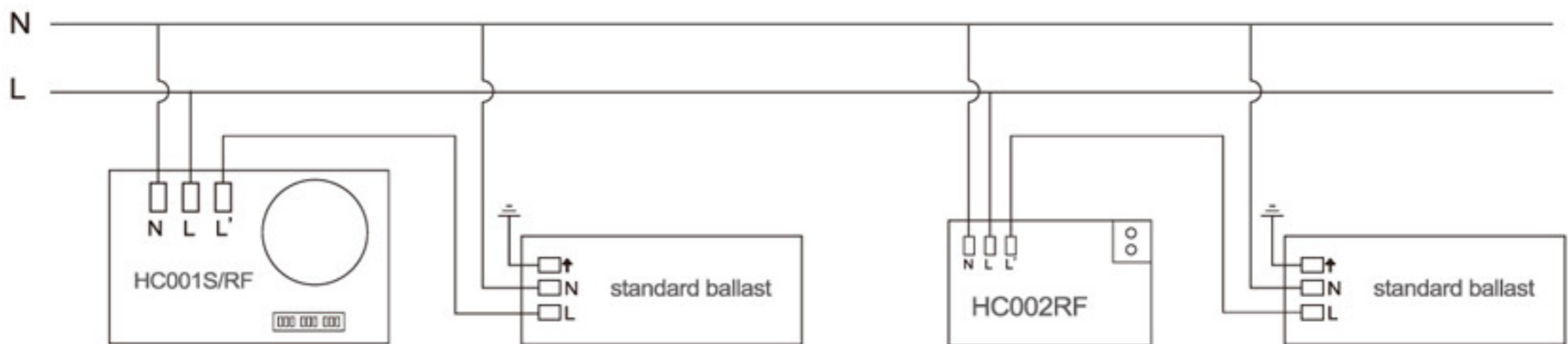

2 : HC001S/RF + HC005RF to have dimming function with HYTRONIK sensorDIM ballast--

This dimming function works with HYTRONIK sensorDIM ballast only. The output signal is connected to the control terminal on the ballast, which switches on the light at 100%, and dims to 10% when the signal passes out.

HYTRONIK sensorDIM ballast has a wide coverage on various models and wattages of plug-in fluorescent lamps, T5, T8, HID lamps as well as all constant current LED lamps.

For detailed information about the sensorDIM ballast, please refer to page 44.

max. Load (inductive load)--

HC005RF:

400w@100v; 800w @ 230v; 1000w @ 277v;

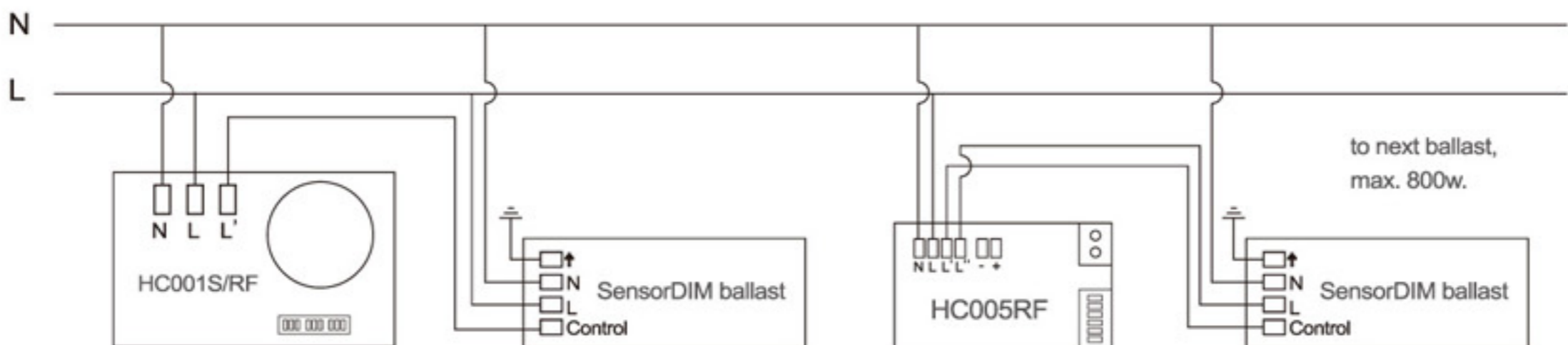

3 : HC001S/RF + HC005RF to have dimming function with any 1-10v dimmable ballast--

This receiver has provided with 1-10v analogue dimming interface for any 1-10v dimmable ballast and control gears--

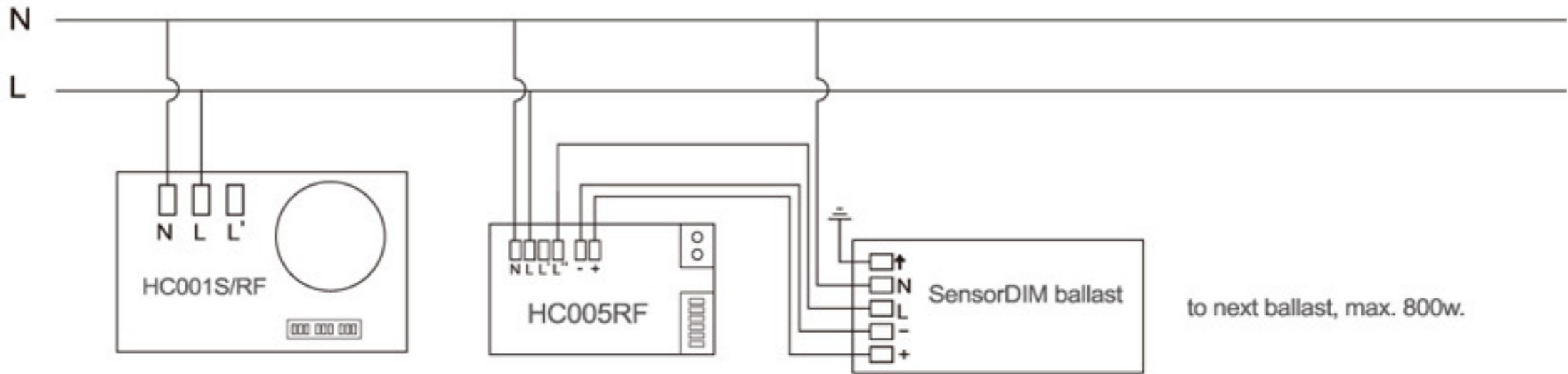

max. Load (inductive load)--

HC005RF: 400w@100v; 800w @ 230v; 1000w @ 277v;

corridor function (HC005 RF)--

Same function as Tridonic Excel ballast, HYTRONIK has built in the corridor function inside the motion sensor instead...



1 Movement of people activates the lamp.

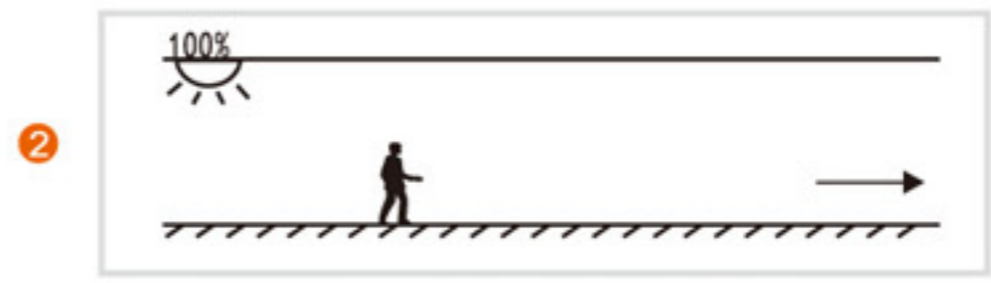

2 Lamp is still on at 100% during the hold time.

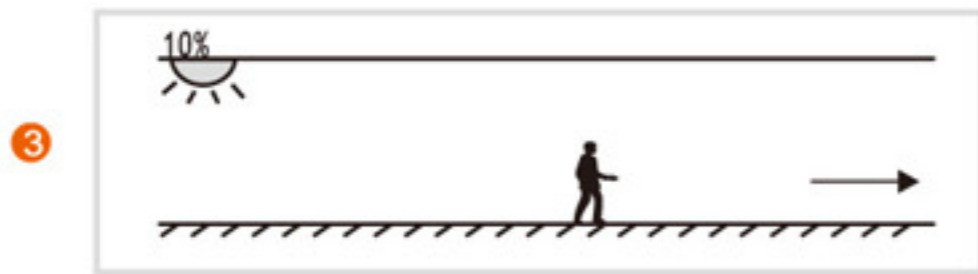

3 Lamp is dimmed to 10% after holdtime, system goes to stand-by period

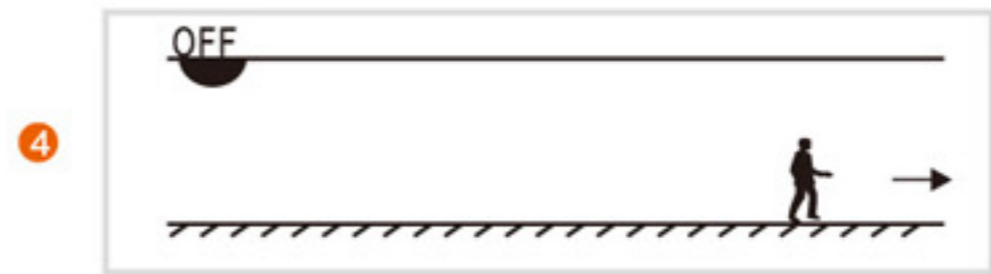

4 Lamp is switched off after the stand-by period

RF transmission:

The motion signal from 1 sensor (the master sensor) can be transmitted to and trigger on other sensors (the slave unit) by RF transmission. This wireless radio wave transmission can reach 50 meters in open area with internal RF antenna. in case, extremely long transmitting distance is required, the external RF antenna can be plugged in the socket and increase the transmitting distance up to 200m in open area.



RF grouping (max. 15 channels):

Thanks to KEELOQ coding system, the setup of communication channel and the definition of masters and slaves can be easily achieved by the "Teach & Learn" method—
(usually the transmitter unit is called "master ", and the receiving unit is called "slave")

A. Press **LEARN** button on the slave unit , the sensors goes into 180s of teach-and-learn period, in which electrician have enough time to go back to master unit to release transmission.

red LED is on after the Learn button is pressed.

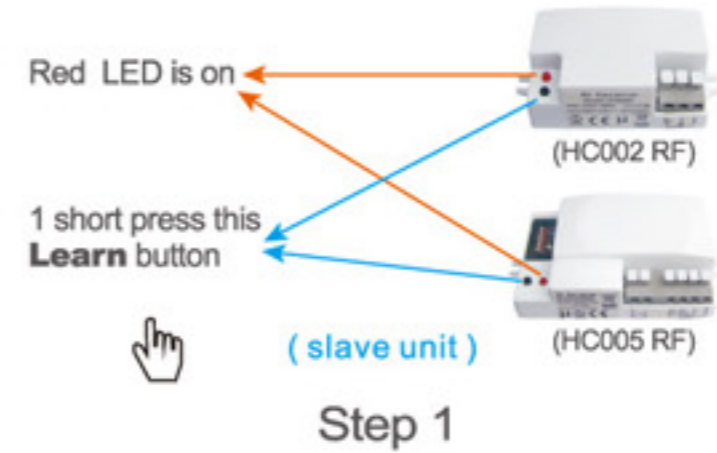

B. Press the **SEND** button on the master unit to send RF signal, the green LED on the master unit is then on to indicate the success of transmission.

Upon receiving the transmission signal, the red LED on slave unit will flash 2-3 times, which is the indication of successful teach-and-learn.

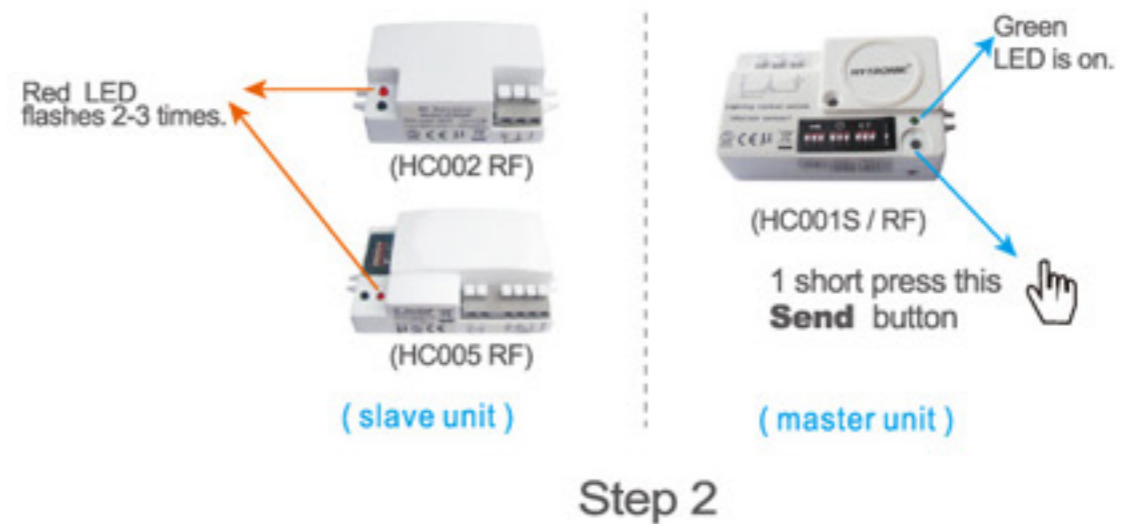

C. Wait for 180s period ellapes, till the red LED on slave unit goes off. The whole teach-and-learn process is completed. Or--

Short press the **Learn** button again within the 180s period to finish the whole teach-and-learn process.

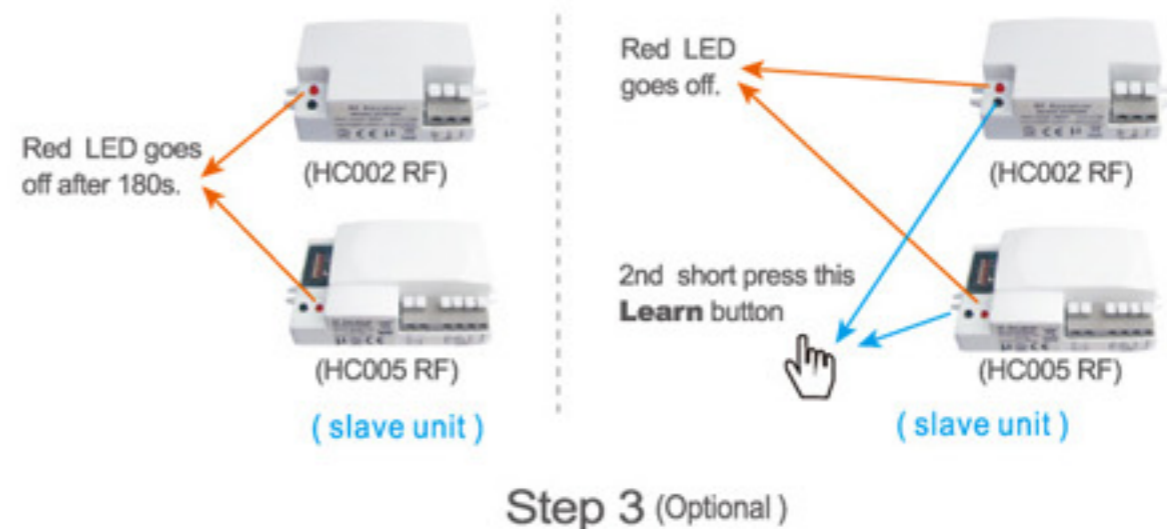

D. A long press on **Learn** button (about 10s) resets and clears all previous commands it has received—

the red LED keeps on flashing and then goes off in the end ; this is the indication of a successful reset and erase of all the previous groupings.

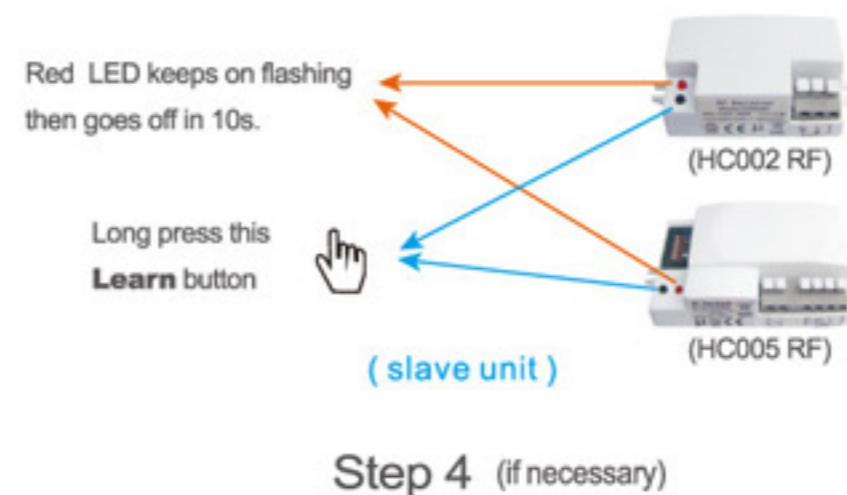

For comfort and efficient of installation, it is highly recommended to finish the grouping work at 1 place in 1 effort before the fixtures are separately installed in different locations.

setup on the transmitter (HC001S /RF)--

a: detection area--

Detection area can be reduced by selection the combination on the DIP switches to fit precisely for each specific application

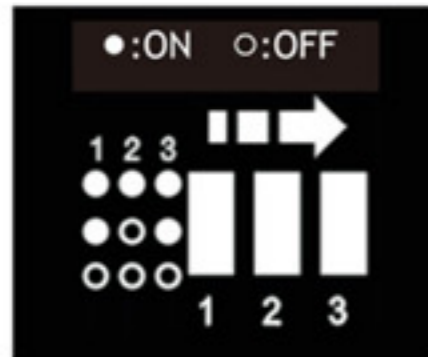

	1	2	3	
I	●	●	●	100%
II	●	○	●	50%
III	○	○	○	10%

b: hold-time--

Hold-time means the time period you would like to keep the lamp on 100% after the person has left the detected area.

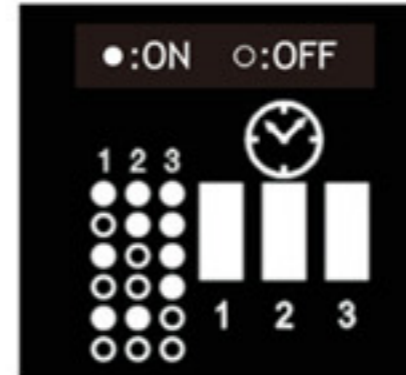

Recommendation

	1	2	3	
I	●	●	●	10s
II	○	●	●	30s
III	●	○	●	1min
IV	○	○	●	5min
V	●	●	○	10min
VI	○	○	○	20min

c: daylight sensor--

The sensor contains a daylight sensor in order to allow a function only below a defined brightness threshold. To set up "brightness threshold"--

"daylight": The lamp works always, even during daylight.

"twilight": The lamp works only in twilight and in darkness.

"darkness": The lamp works only in darkness.

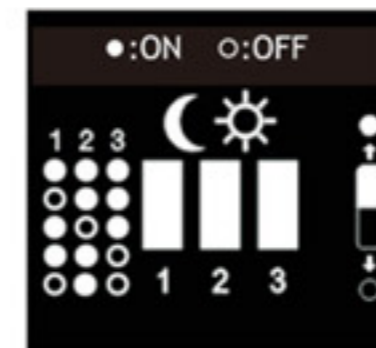

Recommendation

	1	2	3	
I	●	●	●	Disable
II	○	●	●	50Lux
III	●	○	●	30Lux
IV	●	●	○	10Lux
V	○	●	○	2Lux

Disabled Means sensor is always working, even in bright daylight

setup on the reciever (HC005 RF)--

d) Standby time: (disable/1h/30min/10min/1min)

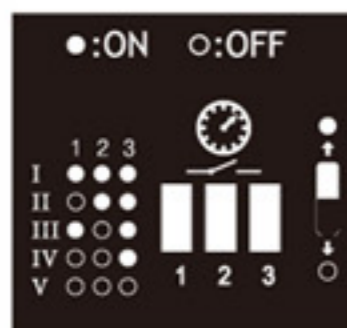

Recommendation

	1	2	3	
I	●	●	●	Disable
II	○	●	●	1h
III	●	○	●	30min
IV	○	○	●	10min
V	○	○	○	1min

e) Standby dimming level: (1-10v DC signal 5V /4V /3V/ 2V/ 1.4V)

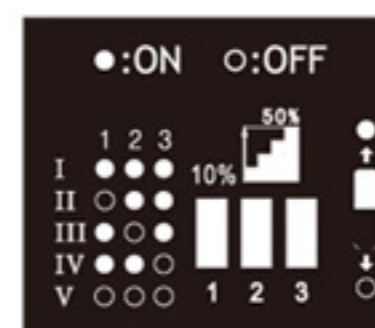

Recommendation

	1	2	3	1-10V DC signal	Brightness
I	●	●	●	5V	45-50%
II	○	●	●	4V	35-40%
III	●	○	●	3V	25-30%
IV	●	●	○	2V	15-20%
V	○	○	○	1.4V	5-10%

6.typical application--

This motion detection in combination with R F feature is an ideal choice for automatic lighting application in the stairwell--

When the first sensor detects motion, it passes on the signal to other members in the group by R F transmission and receiving. So that the lighting ahead can be switched on to 10-50% stand-by status.

In this application--

detection area--100%

motion holdtime--30 s

daylight threshold-- 50 lux

stand-by brightness--10%

stand-by period--60s.

Dimmable ballast-- 1-10v ballast, or sensorDIM ballast.

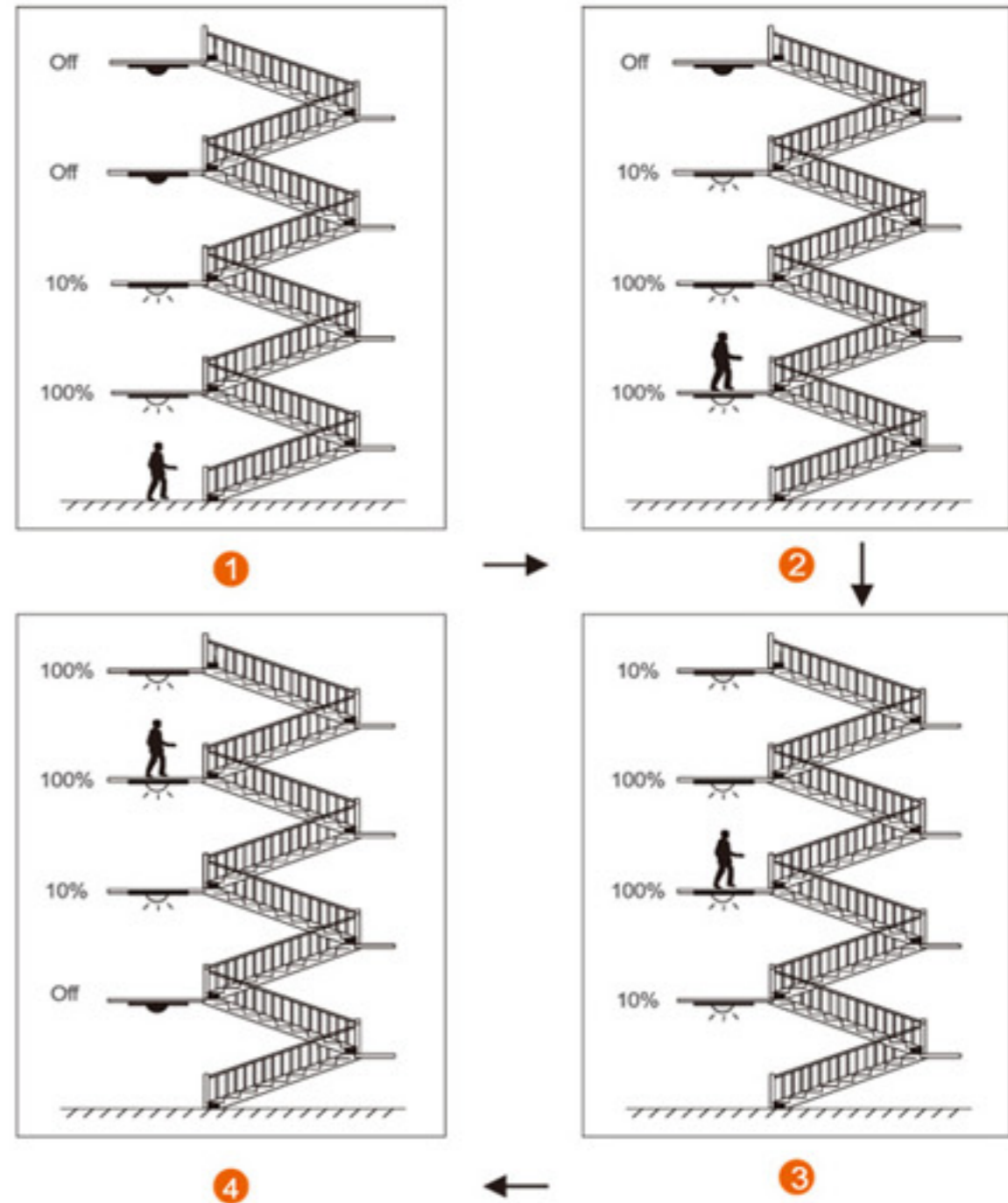

Technical Data

Operating voltage:	HC003V /RF--220-240v ; HC403V /RF--120-277v
Switched power:	HC003V /RF--800w ; HC403V /RF--800w/120v, 1200W/277v.
Coding	Keeloq rolling code (tech/learn/reset/memory)
Detection area	10 / 30 / 50 / 75 / 100% , can be customized
Hold time	5s/30s/1min/5min/10min , can be customized
Daylight threshold	2--2000 lux
RF. Communicatin Chanel	15 channels for grouping
Microwave frequency	5.8 GHz +/- 75 MHz
Microwave power	<1mw
Detection range	Max. (ϕ x H): 16m x 20m
Detection angle	10--150°
RF. Transmission distance	50 meters in open area
Mounting height:	0.5--10m.
Operating temperature:	-20 °C ~ +70 °C
Detection area	433 MHz

Compliance and Marking

EU directives:	Standards:	Safety certification
Nr. 1999/5/EC	IEC61000-4-2	IEC61000-3-2
Nr. 2004/108/EC	IEC61000-4-3	IEC61000-3-3
Nr. 73/23/EEC	IEC61000-4-4	EN60669-2-1
Nr. 2002/95/EC	IEC61000-4-5	EN60669-1
ETSI EN 300 440-2	IEC61000-4-6	CISPR 14
ETSI EN 300 440-1	IEC61000-4-8	CISPR 15
EN 50371	IEC61000-4-11	
EN 60669-2-1 + EN 60669-1(EMP)	ETSI EN 301 489-3 V1.4.1(2002-08)	
ETSI EN 300 220-2 V2.1.2(2007-06)	ETSI EN 301 489-1 V1.8.1(2008-04)	
ETSI EN 300 220-1 V2.1.1(2006-04)		